



.....
Cheetah 36

.....
Disc Drive

.....
ST136403LW/LC
.....

.....
Installation Guide
.....

Contents

Preface	1
Electrostatic discharge protection	2
Important safety information and precautions	3
Wichtige Sicherheitshinweise	5
Regulatory agency compliance	8
General description	10
Kühlung des Systems.....	13
How to install the drive	17
Seagate Technology support services.....	41

©1999 Seagate Technology, Inc. All rights reserved

Publication Number: 83329450, Rev. A

March 1999

Seagate, Seagate Technology, and the Seagate logo are registered trademarks of Seagate Technology, Inc. Cheetah, SeaFAX, SeaFONE, SeaBOARD, and SeaTDD are either trademarks or registered trademarks of Seagate Technology, Inc. or one of its subsidiaries. All other trademarks or registered trademarks are the property of their respective owners.

No part of this publication may be reproduced in any form without written permission from Seagate Technology, Inc.

Preface

This manual contains handling information, support services, performance specifications, and installation information for Seagate® Cheetah 36 SCSI disc drives.

Although you can jump ahead to the installation instructions to get up and running quickly, you may want to read the “General description” section beginning on page 10 to learn more about this drive’s multimode capabilities, data bus details, specifications, and cooling requirements.

Additional information is available in the *Cheetah 36 Product Manual* (part number 83329440). Contact your Seagate sales representative if you need to order this publication.

Handling precautions



- Disc drives are fragile. Do not drop or jar the drive. Use a padded surface during installation to avoid damaging the drive.
- Keep the drive in its antistatic bag until you are ready to install it.
- Protect the drive from static discharge by making sure you are well grounded before touching the drive. We recommend wearing a grounded wrist strap (Seagate part number 12263496) throughout the installation process. Do not touch the connectors or any part of the printed circuit board.
- Always handle the drive by its edges or frame.
- Do not apply pressure or attach labels to the circuit board or the top of the drive.

Electrostatic discharge protection



Caution. Removal of circuit boards by personnel not performing depot repair will damage components and may void the warranty.

All drive electronic assemblies are sensitive to static electricity due to the electrostatically sensitive devices used within the drive circuitry. Although some devices such as metal-oxide semiconductors are extremely sensitive, all semiconductors, as well

as some resistors and capacitors, may be damaged or degraded by exposure to static electricity.

Electrostatic damage to electronic devices may be caused by the direct discharge of a charged conductor or by exposure to the static fields surrounding charged objects. To avoid damaging drive electronic assemblies, observe the following precautions when installing or servicing the drive:

- Ground yourself to the drive whenever the drive electronics are or will be exposed. Connect yourself to ground with a wrist strap (Seagate part number 12263496). Connection may be made to any grounded metal assembly. As a general rule, remember that you and the drive electronics must all be grounded to avoid potentially damaging static discharges.
- Turn off the power before removing or installing the DC power cable.
- Do not remove any circuit boards from the drive.
- Never use an ohmmeter on any circuit boards.
- When installing the drive on a carrier or tray, discharge the carrier or tray prior to inserting it into the system.

Important safety information and precautions



Caution. Use forced-air ventilation when bench-testing the drive to ensure proper cooling of drive components.

Use proper safety techniques for safe, reliable operation of this unit.

- The procedures in this manual and labels on the unit contain warnings and cautions that must be carefully read and fol-

lowed to minimize or eliminate the risk of personal injury. The warnings point out conditions or practices that may endanger you or others. The cautions point out conditions or practices that may damage the unit, possibly making it unsafe for use.

Always observe the following warnings and precautions:

- Follow all cautions and warnings in the procedures.
- Use sound safety practices when operating, installing, or removing the unit.
- Use caution when troubleshooting a unit that has voltages present. Turn off power to the unit before removing it.
- Ensure that the internal temperature of the rack or cabinet does not exceed the limits defined for the drive when the drive is mounted in an equipment rack or cabinet. When units are stacked vertically, pay special attention to the top where temperatures are usually highest.
- Follow the precautions listed above in “Electrostatic discharge protection.”
- Do not remove any circuit boards from the drive. Return the entire drive for depot repair if any circuit board is defective. Removal of circuit boards by personnel not performing depot repair will damage components and may void the warranty.
- Do not separate the head and disc assembly (HDA) from the PCB. Return the entire drive for depot repair if the HDA is defective.
- Do not attempt to disassemble the HDA. It is not field repairable. If the sealed HDA is opened by personnel not performing depot repair, this will damage components and void the warranty.

As a component, this drive is designed to be installed and operated in accordance with UL1950, EN60950, CAN/CSA C22.2 950-M95, and VDE0805.

Seagate takes all reasonable steps to ensure that its products are certifiable to currently accepted standards. Typical applications of these disc drives include customer packaging and subsystem design. Safety agencies conditionally certify component assemblies, such as the Cheetah disc drive, based on their final acceptability in the end-use product. The subsystem designers are responsible for meeting these conditions of acceptability in obtaining safety-regulatory agency compliance in their end-use products and for certifying where required by law. A necessary part of meeting safety requirements is the provision for overcurrent protection on drive SELV supply voltages.

This unit is a component part and as such is not meant to comply with FCC or similar national requirements as a stand-alone unit. Engineering radiated emissions test results are available through the Seagate Safety Department to assist the subsystem designer.

Wichtige Sicherheitshinweise

Vorsicht. Beim Testen des Laufwerks auf dem Prüftisch ist Fremdbelüftung vorzusehen, um eine ausreichende Kühlung der Laufwerkkomponenten sicherzustellen.

Verwenden Sie geeignete Sicherheits- um den sicheren, zuverlässigen Betrieb dieser Einheit zu gewährleisten.

Die Verfahren in diesem Handbuch und die Aufkleber auf dem Gerät enthalten Warn- und Vorsichtshinweise. Diese Hinweise sind sorgfältig durchzulesen und zu beachten, um das Risiko von Verletzungen auf ein Mindestmaß zu beschränken oder ganz zu vermeiden. Die Warnhinweise machen auf Situationen oder Praktiken aufmerk-

sam, die Sie oder andere gefährden könnten. Die Vorsichtshinweise machen auf Situationen oder Praktiken aufmerksam, die Einheit beschädigen können, so daß deren Gebrauch mit Risiko behaftet ist.

Die Warn- und Vorsichtshinweise sind nicht allumfassend! Es ist uns einfach nicht möglich, alle Wartungsmethoden oder die eventuellen Risiken jeder Methode zu kennen, zu beurteilen und Sie entsprechend zu beraten. Aus diesem Grund haben wir auf eine derartige umfassende Beurteilung verzichtet. Falls Sie ein hier nicht beschriebenes Verfahren oder Werkzeug verwenden, stellen Sie zuerst sicher, daß das gewählte Verfahren weder Ihre persönliche Sicherheit noch die Leistung der Einheit gefährdet.

Beachten Sie in jedem Fall die folgenden Warn- und Vorsichtshinweise:

- Beachten Sie alle Warn- und Vorsichtshinweise in diesem Handbuch.
- Treffen Sie beim Betrieb, bei der Installation oder bei der Entfernung der Einheit angemessene Sicherheitsvorkehrungen.
- Wenn eine Einheit unter Spannung steht, gehen Sie bei der Fehlerdiagnose besonders vorsichtig vor. Schalten Sie die Einheit aus, bevor Sie mit den Installations- und Entfernungsarbeiten beginnen.
- Wenn das Laufwerk in einem Einbaugestell oder Gehäuse montiert ist, sorgen Sie dafür, daß die Temperatur im Inneren des Gestells oder Gehäuses die für das Laufwerk vorgegebenen Grenzwerte nicht übersteigt. Wenn Einheiten vertikal übereinander betestigt werden, achten Sie besonders auf den oberen Stapelbereich, da dort die Temperatur gewöhnlich am höchsten ist.
- Befolgen Sie die oben unter "Electrostatic Discharge Protection" angegebenen Sicherheitsmaßnahmen.
- Nehmen Sie keine Platinen aus dem Laufwerk. Wenn eine Platine defekt ist, muß das gesamte Laufwerk zur Reparatur eingeschickt werden. Die Herausnahme von Platinen durch andere Personen als die für die werkseitige Reparatur zuständigen kann zu einer Bes-

chädigung der Komponenten und Erlöschen des Garantieanspruchs führen.

- Die vormontierte Kopf- und Festplatteneinheit (HDA) nicht aus dem Laufwerkgehäuse nehmen! Falls die HDA beschädigt ist, schicken Sie das gesamte Laufwerk zur Reparatur ein.
- Die HDA ist nicht vor Ort reparierbar und darf nicht auseinandergenommen werden! Öffnen der versiegelten HDA durch andere Personen als die für die werkseitige Reparatur zuständigen hat eine Beschädigung der Komponenten und Erlöschen des Garantieanspruchs zur Folge.

Als Teilkomponente ist dieses Laufwerk für die Installation und den Betrieb in Übereinstimmung mit UL 1950, EN60950, CAN\CSA C22.2 950-M95 und VDE0805 vorgesehen.

Seagate ist ständig bemüht, die Zulassungsfähigkeit von Seagate-Produkten im Rahmen der gegenwärtig geltenden Standards zu gewährleisten. Zu den typischen Anwendungen dieser Festplattenwerke zählen Systemeinbau durch den Kunden und die Konstruktion von Untersystemen. Sicherheitsbehörden gewähren eine bedingte Zulassung für Komponenten wie das Cheetah-Festplattenlaufwerk vorbehaltlich der endgültigen Zulassung im Endprodukt. Designer von Untersystemen sind dafür verantwortlich, die Voraussetzungen für die Einhaltung sicherheits- oder aufsichtsbehördlicher Vorschriften in ihren Endprodukten und - falls gesetzlich vorgeschrieben - für die Zulassung zu schaffen. Eine Grundvoraussetzung zur Einhaltung der Sicherheitsanforderungen ist die Bereitstellung eines Überlastschutzes für die SELV-Versorgungsspannungen des Laufwerks.

Dieses Gerät ist eine Baugruppe und unterliegt als solche nicht den Anforderungen der FCC oder ähnlicher nationaler Behörden für eigenständige Geräte. Technische Testergebnisse zu elektromagnetische Strahlung sind für Designer von Untersystemen auf Anfrage von der Seagate-Sicherheitsabteilung erhältlich.

Regulatory agency compliance

Electromagnetic susceptibility

As a component assembly, the drive is not required to meet any susceptibility performance requirements. It is the responsibility of those integrating the drive within their systems to perform those tests required and design their system to ensure that equipment operating in the same system as the drive or external to the system does not adversely affect the performance of the drive. See DC power requirements on page 16.

Electromagnetic compliance

Seagate uses an independent laboratory to confirm compliance to the directives/standard(s) for CE Marking and C-Tick Marking. The drive was tested in a representative system for typical applications. The selected system represents the most popular characteristics for test platforms. The system configurations include:

- 486, Pentium, and PowerPC microprocessors
- 3.5-inch floppy disc drive
- Keyboard
- Monitor/display
- Printer
- External modem
- Mouse

Although the test system with this Seagate model complies to the directives/standard(s), we cannot guarantee that all systems will comply. The computer manufacturer or system integrator shall confirm EMC compliance and provide CE Marking and C-Tick Marking for their product.

Electromagnetic compliance for the European Union

If this model has the CE Marking it complies with the European Union requirements of the Electromagnetic Compatibility Directive 89/336/EEC of 03 May 1989 as amended by Directive 92/31/EEC of 28 April 1992 and Directive 93/68/EEC of 22 July 1993.

Australian C-Tick

If this model has the C-Tick Marking it complies with the Australia/New Zealand Standard AS/NZS3548 1995 and meets the Electromagnetic Compatibility (EMC) Framework requirements of Australia's Spectrum Management Agency (SMA).

General description

Cheetah 36 SCSI disc drives are high-speed, random-access digital-data storage devices capable of operating in single-ended (SE) or low voltage differential (LVD) modes.

This multimode capability allows you to use this drive in systems that use the traditional SE technology or in LVD-capable systems.

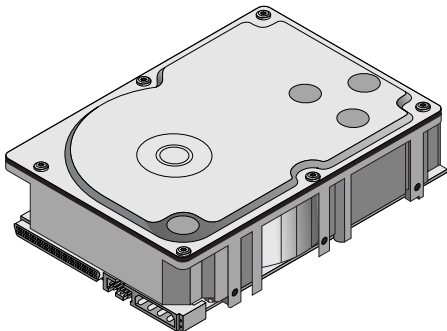

Figure 1. Cheetah 36 family drive (LW model shown)

This drive should be mounted in an enclosure designed for the drive. This is often within the host system case or an external enclosure designed to house one or more disc drives or other devices. In either case, the disc drive must receive adequate cooling (refer to “Providing adequate cooling”) and it must be sufficiently grounded and shielded from emissions. The *Cheetah 36 Product Manual* (part number 83329440) contains guidelines for a properly designed enclosure.

Single-ended and low voltage differential modes

This drive incorporates two different transceivers to allow you to use it in systems which use single-ended (SE) drivers and receivers, or in low voltage differential (LVD) capable systems which use LVD drivers and receivers.

The primary benefits of LVD technology

- Faster transfer rates.
- Reduces power consumption.
- Increases allowable cable lengths.
- Improves device connectivity.

You can configure the drive to switch between SE and LVD modes automatically or force it to operate in SE mode only. To configure this option, use the jumper illustration on page 24 (LW models) or page 34 (LC models).

Note. To operate at the Ultra2 SCSI rates in LVD mode, all devices on the same bus must be running in LVD mode. If you add any single-ended device to a bus that is operating in LVD mode, all devices drop back to operating in single-ended mode. This eliminates the possibility of reaching Ultra2 SCSI transfer rates.



Caution. Do not mix LVD drives on the same bus with devices having high voltage differential (HVD) interface circuits. The circuits are not compatible and drive damage may occur.

Data bus widths

These drives have a wide (16-bit) SCSI data bus. You can use these drives on a non-wide (8-bit) data bus if you provide proper termination to the upper eight data lines. This is often referred to as providing “high-9 termination” (the other bit is for parity).

The following table lists the maximum cable lengths and number of devices using single-ended and LVD I/O circuits.

Table 1. SE and LVD bus configurations

SCSI driver type	I/O transfer rate (Mbytes/s)	Maximum number of devices on bus	Maximum cable length allowed
SE	20	16	6 meters (19.7 ft.)
SE	40	4	3 meters (9.8 ft.)
SE	40	8	1.5 meters (4.9 ft.)
LVD	80	16	12 meters (39.4 ft.)

Providing adequate cooling

The enclosure design must ensure adequate cooling for the drive. The maximum ambient temperature allowed is 50°C.

The drive’s product manual (83329440) describes how to evaluate the air-flow design. The evaluation consists of ensuring that the case temperature of certain critical components remains within acceptable limits during drive operation.

Figure 2 shows two design approaches with one or more fans used to generate air flow. The air-flow patterns can be created

by the fans either pushing or drawing air. The overall flow pattern can be directed from front to back, back to front, or side to side.

Kühlung des Systems

Die Gehäusekonstruktion muß eine ausreichende Kühlung des Laufwerkes gewährleisten. Die Umgebungstemperatur darf maximal 50°C betragen.

Die Produkthandbuch Cheetah 36 (Dokument 83329440) enthalten Anweisungen zur Beurteilung der Luftstromkonstruktion. Die Beurteilung muß sicherstellen, daß sich die Gehäusetemperatur bestimmter kritischer Komponenten bei Laufwerkbetrieb innerhalb zugelassener Grenzen hält.

Abbildung 2 zeigt zwei Konstruktionsmöglichkeiten, bei denen ein oder mehrere Lüfter den Luftstrom erzeugen. Der Luftstromverlauf wird durch die Lüfter gesteuert, die entweder Luft einblasen oder abziehen. Generell kann der Luftstrom entweder von vorne nach hinten oder von hinten nach vorne verlaufen.

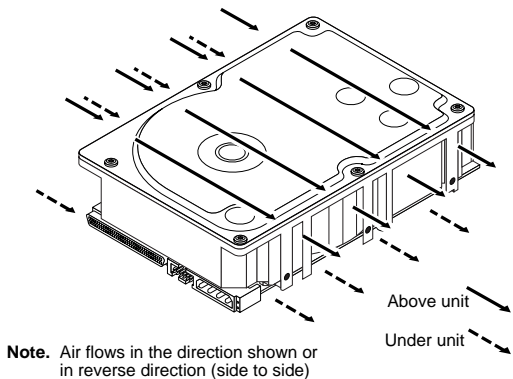
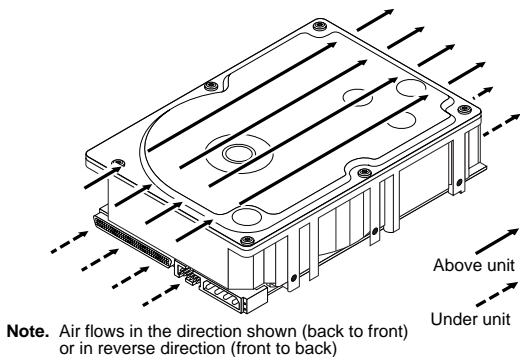

Figure 2. Suggested air flow

Abbildung 2. Empfohlener Luftstromverlauf

Characteristics	ST136403LW/LC
Interface	Ultra2 SCSI ¹
Capacity	
Unformatted (Gbytes)	43.2
Formatted (Gbytes) ²	36.4
Recording	
Cylinders (user)	9,801
Read/write data heads	24
Avg bytes/track	153,284 - 229,045
Access time ³	
Average read (msec)	6.15
Average write (msec)	6.85
Disc rotation	
RPM	10,016
Average latency (msec)	2.99
Synchronous data transfer rate	
Maximum instantaneous (Mbytes/sec)	40 (SE mode) 80 (LVD mode)
Asynchronous data transfer rate	
Maximum instantaneous (2 bytes wide) (Mbytes/sec)	10.0
Multi-segmented cache (kbytes)	1,024 standard 4,096 optional

1. Also operates per SCSI-1/SCSI-2/SCSI-3 protocols.
2. The specified formatted capacities are calculated with the standard OEM sector size (512 bytes per logical block) and sparing.
3. Includes on-board controller overhead.

DC power requirements ($\pm 5\%$)¹	Single-ended (SE) mode		Low voltage differential (LVD) mode	
	+5 V	+12 V	+5 V	+12 V
ST136403LW/LC				
Maximum start current	0.83	2.3	0.85	2.3
Maximum operating current	0.84	1.6	0.88	1.6
Average idle current	0.75A	0.99A	0.77A	0.99A

- For more detailed power information, refer to the Cheetah 36 Product Manual, publication number 83329440.

How to install the drive

This installation guide provides step-by-step instructions to make your drive installation as easy as possible. Follow the installation steps listed for your drive model as listed below:

LW models (use the installation steps beginning below).

LC models (use the installation steps beginning on page 30).

LW model installation

1. Set the SCSI ID on the drive.

Determine which SCSI IDs are already being used in the system and then assign this disc drive a SCSI ID that isn't already being used. Use the J6 connector located on the front of the drive to set the SCSI ID (see Figure 3).



- This drive is SCAM (SCSI Configured AutoMatically) compliant. If you are installing this drive in a SCAM compliant system, you can skip this step because the system automatically assigns the drive SCSI ID.
- The host system's SCSI controller usually uses SCSI ID 7 so this SCSI ID is not usually available for disc drives or other devices.
- Most ST136403LW drives are factory set with the SCSI ID set at 0. If this is the only SCSI drive in your system and there are no other SCSI devices on the daisychain, you can leave this drive's SCSI ID set to 0 and proceed to the next step. A device is any hardware other than an inline terminator that is connected to the SCSI cable.

2. Configure termination.

If you are installing the drive in a system that has other SCSI devices installed, terminate only the end devices on the SCSI bus.

Figure 4 shows the three most common termination configurations. LW model drives do not have internal terminators or any other way of adding internal termination on the drive. You must provide external termination to these drives when termination is required. This is normally done by adding an in-line terminator on the cable. See Figure 9 on page 27 for an illustration showing a system configuration that uses an inline terminator.



- Use active (ANSI SCSI-2 Alternative 2) single-ended terminators when terminating a bus operating in single-ended mode.
- Use SPI-2-compliant active low voltage differential terminators when terminating a SCSI Ultra2 bus operating in LVD mode.
- Some controllers prefer to remain terminated even if they are in the middle of the chain. Also, some controllers treat the internal and external chains as separate logical buses. This means you may need to terminate both the first and last devices on both logical buses to achieve proper termination. If necessary, refer to your system or controller documentation to see how this is handled in your particular system.

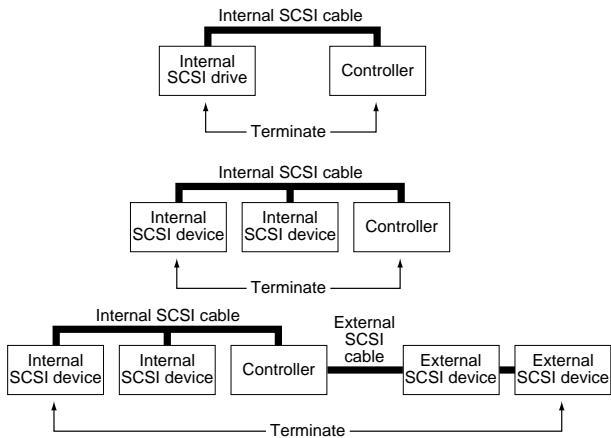

Figure 4. SCSI bus termination

4. Connect the drive activity remote LED (optional)

This drive provides connections for a remote drive activity LED. This step is optional because the drive will work fine without an LED connected, but many people find this to be helpful to determine when the drive is actively reading or writing data.

Most host systems provide this LED which is a small “bulb” (actually a light-emitting diode) located on the host’s front panel. Simply locate this LED and connect the attached pair of wires to the pins on the drive as shown in Figure 6 below.

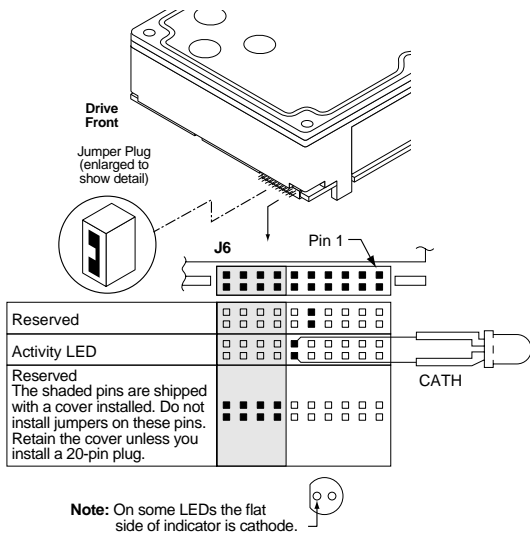

Figure 6. Drive Active LED indicator connections

5. Check the other available jumper settings (optional)

This drive provides several features for unique configurations. You will not normally need to change from the default settings for normal operation. See Figure 7 on page 24.

Single-ended mode option

You can force the drive to operate only in SE mode by installing a jumper on J2 pins 15 and 16. The default is to allow the drive to automatically detect and use SE or LVD mode. See page 11 for a description of these two modes.

Delay Motor Start and Motor Start options

You can control when the drive's motor starts spinning the media using these two jumper positions (J2 pins 11 and 12 and J2 pins 13 and 14). You can configure the drive to delay spinning up until a certain number of seconds elapse or until the drive receives a Start Unit command from the host system. The default settings are with both off so that the drive begins spinning up as soon as it receives power.

Write Protect option

You can install a jumper connecting J2 pins 9 and 10 to prevent anyone from writing data to this disc drive (users can still read data from the drive). This jumper is normally left off to allow users to write data to the drive.

Parity Check option

You can disable parity checking by installing a jumpers on J2 pins 7 and 8. Most systems prefer that parity checking remain enabled. Refer to your host adapter or system documentation to determine whether your host adapter supports parity checking.

Reserved	
Single-Ended Mode option	
Use single-ended or low voltage differential mode.	
Force the drive to operate only in single-ended mode.	
Delay Motor Start option (valid only if the Enable Motor Start jumper is not connected)	
Disable the Delay Motor Start option (default).	
Motor start delay equal to the SCSI ID multiplied by 12 seconds. For example, if the SCSI ID = 2, the drive starts in 24 seconds.	
Motor Start option	
Disable motor start (default). The drive starts according to the Delay Motor Start option.	
Enable motor start. The drive waits for the Start Unit command from the host before starting the spindle motor.	
Write Protect option	
Write protect = Off (enables writing – default).	
Write protect = On (disables writing).	
Parity Check option	
Enable parity check of SCSI bus (default).	
Disable parity check.	

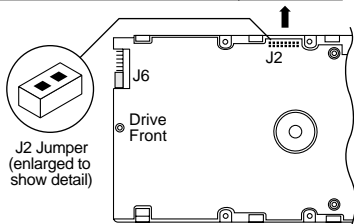

Figure 7. Additional jumper options

6. Mount the drive in the host system and connect cabling.

- a. Mount the drive to the host system's chassis using four 6-32 UNC screws. Two mounting holes are in each side of the drive and there are four mounting holes in the bottom of the drive. Do not over-tighten or force the screw if it does not seem to screw in easily. The dimensions of the drive are provided in Figure 10.
- b. Connect the SCSI cable into the drive's SCSI connector as illustrated in Figure 8 on page 26. Take care not to stretch or crimp this cable, and do not block the system's air flow with the cable. Figure 9 on page 27 shows an example of how to connect multiple drives on the same bus.
- c. Connect the DC power cable to the drive as illustrated in Figure 8.
- d. Replace the host system's cover.



- Do not touch the connector pins or any components on the circuit board.
- Observe static-discharge precautions.
- Always handle the drive by the frame only.
- The drive may be mounted in any orientation; however, you must ensure that the drive receives adequate air flow for cooling.

7. Format the drive.

Follow the instructions on page 37 to format the drive.

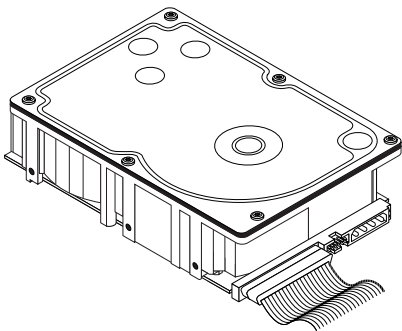
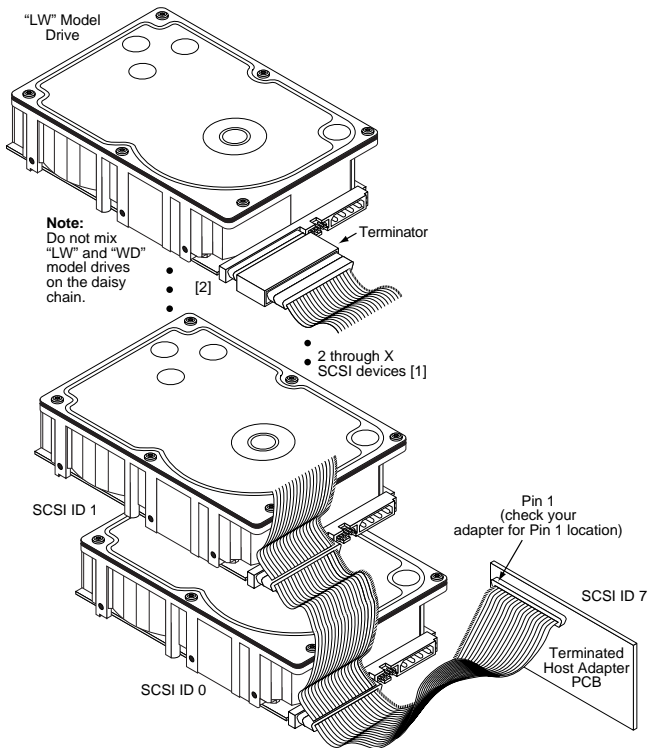

Figure 8. Connecting cables to the drive



[1] "X" means up to 15 devices on the SCSI bus.

[2] External terminator. Used only on end "LW" drive. Use only SPI-2-compliant active LVD terminators on SCSI Ultra2 buses.

Figure 9. Multiple-drive connection to host adapter

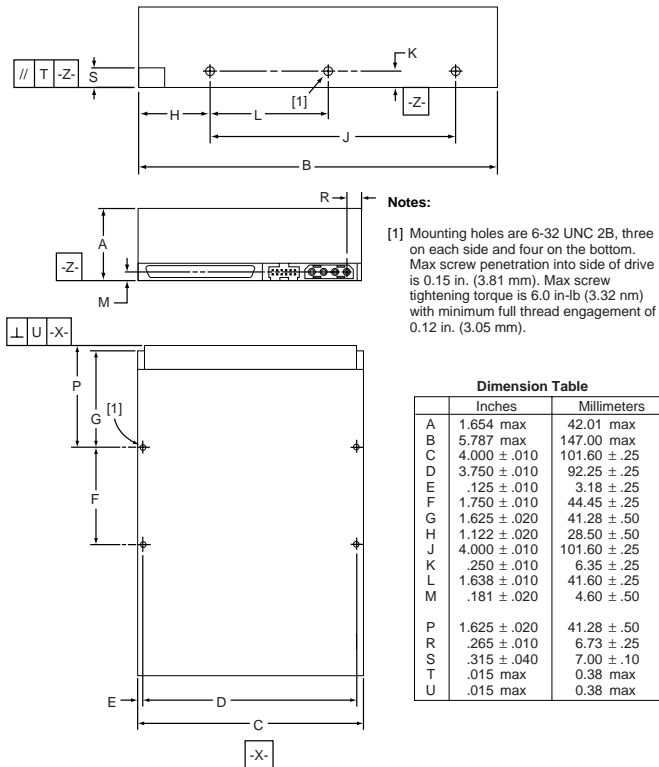

Figure 10. Mounting configuration dimensions (LW model)

Additional connector on LW model drives

LW model drives have a connector located between the SCSI I/O connector and the DC power connector to allow you to set the SCSI ID and connect LEDs from the back of the drive. You are not required to use this connector, but it's available if you want to use it. Refer to Figure 11 for pin assignments.

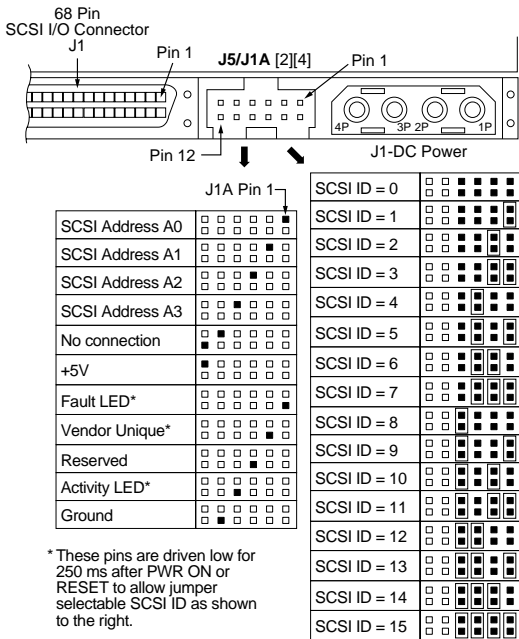

Figure 11. Alternate SCSI ID select and LED connection

LC model installation

1. Set the SCSI ID on the drive.

Determine which SCSI IDs are already being used in the system and then assign the disc drive a SCSI ID that isn't already being used. Use the J6 connector located on the front of the drive to set the SCSI ID (see Figure 12).



- This drive is SCAM (SCSI Configured Auto Magically) compliant. If you are installing this drive in a SCAM compliant system, you can skip this step because the system automatically assigns the drive SCSI ID.
- The host system's SCSI controller usually uses SCSI ID 7 so this SCSI ID is not usually available for disc drives or other devices.
- Most ST136403LC drives are factory set with the SCSI ID set at 0. If this is the only SCSI drive in your system and there are no other SCSI devices on the daisychain, you can leave this drive's SCSI ID set to 0 and proceed to the next step. A device is any hardware other than an inline terminator that is connected to the SCSI cable.

2. Configure termination.

LC model drives are designed for installation in host systems that have a backplane with single connector attachment (SCA) connections. Termination is normally provided on this backplane. Check your host system documentation for details.



- You can use this drive in host systems that do not have a backplane with SCA connectors by using a SCA to wide SCSI-2 adapter. These adapters separate the interface lines from the power lines. If you use such an adapter, proceed with step 2 of the installation instructions provided for LW model drives.

Note. Host systems designed to use LC drives normally provide termination power from the host adapter or other source. LC model drives cannot be configured to provide termination power to the bus.

3. Check the other available jumper settings (optional)

This drive provides several features for unique configurations. You will not normally need to change from the default settings for normal operation. See Figure 13 on page 34.

Single-ended mode option

You can force the drive to operate only in SE mode by installing a jumper on J2 pins 15 and 16. The default is to allow the drive to automatically detect and use SE or LVD mode. See page 11 for a description of these two modes.

Delay Motor Start and Motor Start options

You can control when the drive's motor starts spinning the media using these two jumper positions (J2 pins 11 and 12 and J2 pins 13 and 14). You can configure the drive to delay spinning up until a certain number of seconds elapse or until the drive receives a Start Unit command from the host system. The default settings are with both off so that the drive begins spinning up as soon as it receives power.

Write Protect option

You can install a jumper connecting J2 pins 9 and 10 to prevent anyone from writing data to this disc drive (users can still read data from the drive). This jumper is normally left off to allow users to write data to the drive.

Parity Check option

You can disable parity checking by installing a jumpers on J2 pins 7 and 8. Most systems prefer that parity checking remain enabled. Refer to your host adapter or system documentation to determine whether your host adapter supports parity checking.

4. Mount the drive in the host system.

To mount an LC model drive, plug the drive into the system's single connector attachment (SCA) position on the system's backplane. The SCA connector on the drive contains interface and power functions, so it does not require a separate power connector. The dimensions of the drive are provided in Figure 15.

Some host systems require that you first mount the drive to a sliding tray or courier before inserting it into the system.

This drive model plugs directly into a backplane connector and therefore does not use cables.

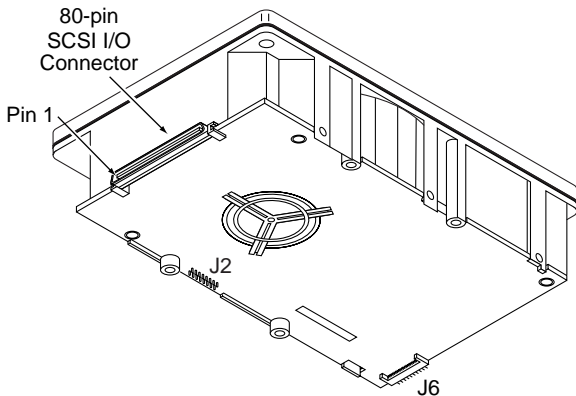
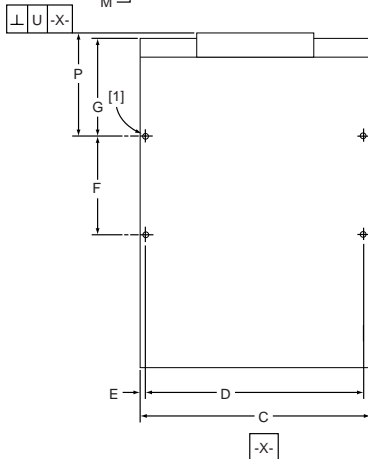
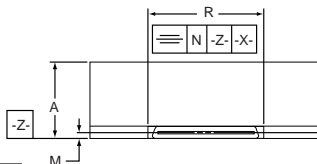
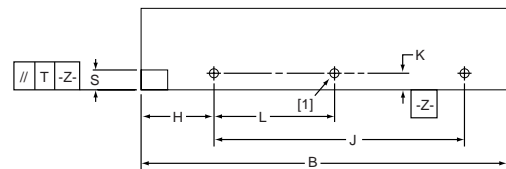

Figure 14. 80-pin I/O connection to drive (LC model)

**Notes:**

- [1] Mounting holes are 6-32 UNC 2B, three on each side and four on the bottom. Max screw penetration into side of drive is 0.15 in. (3.81 mm). Max screw tightening torque is 6.0 in-lb (3.32 nm) with minimum full thread engagement of 0.12 in. (3.05 mm).

Dimension Table

	Inches	Millimeters
A	1.654 max	42.01 max
B	5.787 max	147.00 max
C	4.000 ± .010	101.60 ± .25
D	3.750 ± .010	92.25 ± .25
E	.125 ± .010	3.18 ± .25
F	1.750 ± .010	44.45 ± .25
G	1.625 ± .020	41.28 ± .50
H	1.122 ± .020	28.50 ± .50
J	4.000 ± .010	101.60 ± .25
K	.250 ± .010	6.35 ± .25
L	1.638 ± .010	41.61 ± .25
M	.181 ± .020	4.60 ± .50
N	.040 max	1.20 max
P	1.625 ± .020	41.28 ± .50
R	2.618 ± .010	66.50 ± .25
S	.276 ± .040	7.00 ± 1.02
T	.015 max	0.38 max
U	.015 max	0.38 max

Figure 15. Mounting configuration dimensions (LC model)

5. Format the drive.



Caution. Formatting a drive erases all user data. Be sure that you understand this principle before formatting any hard disc drive. It is not necessary to format a drive that previously has been used to store data unless your intention is to erase all user data. Seagate is not responsible for lost user data.

Important information about formatting the drive

- The drive has been low level formatted at the factory. You do not need to perform another low level format on this drive unless you decide to perform certain diagnostics through the host adapter.
- If you do decide to perform a low level format, do not abort the format as this is likely to make the drive inoperable. A low level format will typically take less than 30 minutes.
- Protect against power failure or other power interruptions during the format.

Cheetah 36 disc drives are designed to operate with a variety of operating systems. Some brief instructions are provided below for DOS, Windows 3.1, Windows 95, Windows 98, and Macintosh systems. For more detailed instructions, or if your operating system is not covered by these instructions, please refer to your operating system or drive utility documentation.

Note. Hardware platform, operating system, and host adapter variations can limit access to the full capacity of this and other high capacity drives. Refer to your system, host adapter, or drive utility documentation for detailed instructions.

DOS, Windows 3.1, Windows 95, and Windows 98

System preparation

- a. Turn your computer on. As your computer starts up, watch the screen for a message describing how to run the system setup program (sometimes called BIOS or CMOS setup). This is usually done by pressing a special key, such as **DELETE**, **ESC**, or **F1** during startup. See your computer manual for details. Press the appropriate key to run the system setup program.
- b. Set the drive type in your BIOS or CMOS setup to “Zero,” “None,” or “No hard drive installed” and then save and exit from your setup program.

Drive partitioning

Partitioning a hard drive divides it into sections (partitions) that act as separate logical drives (labeled C, D, E, etc.). To partition your new drive:

- a. Insert a bootable DOS diskette into your diskette drive and restart your computer.
- b. Insert a DOS program diskette that contains the `fdisk.exe` and `format.com` programs into your diskette drive. At the **A:** prompt, type **fdisk** and press **ENTER**.
- c. If you have two hard drives installed, the `fdisk` menu displays five options. Option five allows you to select

the drive you want to partition. Make sure that your new drive is selected. If you accidentally repartition your old hard drive, you will erase all data on the drive.

- d. Press **1** to select “Create DOS partition or logical DOS drive” and then press the **ENTER** key.
- e. Press **1** again to select “Create primary DOS partition” and then press the **ENTER** key. Create your first drive partition.
If you are creating a partition that will be used to boot your computer (drive C:), make sure that the partition is marked *active*.
- f. Create an extended partition and additional logical drives, if necessary, until all the space on your new hard drive has been partitioned.
- g. When the partitioning is complete, fdisk reboots your computer.

Drive formatting

- a. At the **A:** prompt, type **format x** where **x** is the letter of your new partition. If this is your boot drive, type **format x: /s**. Make sure you use the correct drive letter. If you format a drive that already contains data, you will erase all data on the drive.
- b. Repeat this process for all the new partitions you have created.

After you format your new drive, it is ready to use. You're done!

Macintosh

Use a third-party drive utility to initialize the drive and follow the instructions provided with the utility. Note: versions of Apple Drive Setup prior to version 1.3.1 do not recognize non-Apple drives.

Seagate Technology support services

Online Services

Internet

For online information about Seagate products, visit www.seagate.com or e-mail your disc or tape questions to:

Presales Support:

Disc: http://www.seagate.com/support/email/email_presales.shtml or DiscPresales@Seagate.com

Tape: http://www.seagate.com/support/email/email_tape_presales.shtml or
Tape_Sales_Support@Seagate.com

Technical Support:

Disc: http://www.seagate.com/support/email/email_disc_support.shtml or DiscSupport@Seagate.com

Tape: http://www.seagate.com/support/email/email_tape_support.shtml or TapeSupport@Seagate.com

SeaBOARD[®] is a computer bulletin board system that contains information about Seagate disc and tape drive products and is available 24 hours daily. Set your communications software to eight data bits, no parity and one stop bit (8-N-1). This service is available worldwide.

Automated Services

SeaFONE[®] (1-800-SEAGATE) is Seagate's toll-free number (1-800-732-4283) to access our automated self-help services. Using a touch-tone phone, you can find answers to service

phone numbers, commonly asked questions, troubleshooting tips and specifications for disc drives and tape drives 24 hours daily. International callers can reach this service by dialing +1-405-936-1234.

SeaFAX[®] is Seagate's automated FAX delivery system. Using a touch-tone phone, you can obtain technical support information by return FAX 24 hours daily. This service is available worldwide.

Presales Support

Our Presales Support staff can help you determine which Seagate products are best suited for your specific application or computer system.

Seagate Express

You can purchase select tape products and tape accessories through Seagate Express 24 hours daily by calling 1-800-531-0968 or by faxing your order to: +1-972-481-4812.

Technical Support

If you need help installing your drive, consult your dealer. Dealers are familiar with their unique system configurations and can help you with system conflicts and other technical issues. If you need additional help, you can talk to a Seagate technical support specialist. Before calling, note your system configuration and drive model number (STxxxxx).

SeaTDD[™](+1-405-936-1687) is a telecommunications device for the deaf (TDD). You can send questions or comments 24 hours daily and exchange messages with a technical support

specialist from 8:00 A.M. to 12:15 P.M. and 1:30 P.M. to 6:00 P.M. (central time) Monday through Friday.

Customer Service (CSO)

Warranty Repair

Seagate offers worldwide customer support for Seagate drives. Seagate direct OEM, Distribution and System Integrator customers should contact their Seagate service center representative for warranty information. Other customers should contact their place of purchase.

Authorized Service Centers

If you live outside the U.S., you can contact an Authorized Service Center for service or repair.

USA/Canada/Latin America Support Services

Presales Support

Disc: 1-877-271-3285 or FAX: +1-405-936-1683
+1-405-936-1210

Tape: 1-800-626-6637 or FAX: +1-714-641-2410
+1-714-641-2500

Technical Support (SeaFONE)

1-800-SEAGATE or +1-405-936-1234 (for specific product phone number)

FAX: *Disc:* +1-405-936-1685; *Tape:* +1-405-936-1683

SeaFAX 1-800-SEAGATE

SeaTDD +1-405-936-1687

SeaBOARD *Disc:* +1-405-936-1600; *Tape:* +1-405-936-1630

Warranty Repair

USA/Canada	1-800-468-3472	FAX: +1-405-949-6740
Latin America	+1-405-949-7758	FAX: +1-405-949-6738

Authorized Service Centers**Brazil**

<i>MA Informatica</i>	+55-21-516-6649	FAX: +55-21-516-5280
-----------------------	-----------------	----------------------

Canada

<i>Memofix</i>	+1-905-660-4936	FAX: +1-905-660-4951
<i>Adtech</i>	+1-905-812-8099 or 1-800-624-9857	FAX: +1-905-812-7807

European Support Services

For European customer support, dial the toll-free number for your specific country for presales support, technical support, SeaFAX and warranty repair.

If your country is not listed here, dial our European call center at +31-20-316-7222 from 8:30 A.M. to 5:00 P.M. (European central time) Monday through Friday. The European call center is located in Amsterdam, The Netherlands.

Call Center

Austria	0 800-20 12 90
Belgium	0 800-74 876
Denmark	80 88 12 66
France	0 800-90 90 52
Germany	0 800-182 6831
Ireland	1 800-55 21 22
Italy	1 677 90 695
Netherlands	0 800-732 4283

Norway	800-113 91
Poland	00 800-311 12 38
Spain	900-98 31 24
Sweden	0 207 90 073
Switzerland	0 800-83 84 11
Turkey	00 800-31 92 91 40
United Kingdom	0 800-783 5177

SeaBOARD

Germany	+49-89-1409331
---------	----------------

Fax Services—All European Countries

Presales/Technical Support/Warranty Repair +31-20-653-3513

Africa/Middle East Support Services

For presales, technical support, warranty repair and FAX services in Africa and the Middle East, dial our European call center at +31-20-316-7222 from 8:30 a.m. to 5:00 p.m. (European central time) Monday through Friday, or send a FAX to +31-20-653-3513. The European call center is located in Amsterdam, The Netherlands.

Asia/Pacific East Support Services

Technical Support

Australia	+61-2-9725-3366	FAX: +61-2-9725-4052
Hong Kong	+852-2368 9918	FAX: +852-2368 7173
Japan	—	FAX: +81-3-5462-2979
Singapore	+65-488-7584	FAX: +65-488-7528
Taiwan	+886-2-2514-2237	FAX: +886-2-2715-2923

SeaFAX

Australia +61-2-9756-5170

Warranty Repair

Japan +81-3-5462-2904 FAX: +81-3-5462-2979

Asia/Pacific and +65-485-3595 FAX: +65-488-7503

Australia



Seagate Technology, Inc.

920 Disc Drive, Scotts Valley, CA 95066-4544, USA

Publication Number: 83329450, Rev. A, Printed in USA